

NOTES:

- 1.) Post size depends on fence height and wind loads. See *MONTAGE II* specifications for post sizing chart and setting dimensions.
- 2.) Third & Forth rail optional.
- 3.) Available in Flush Bottom.

RAKING DIRECTIONAL ARROW
 Welded panel can be raked 30° over 8' with arrow pointing down grade.

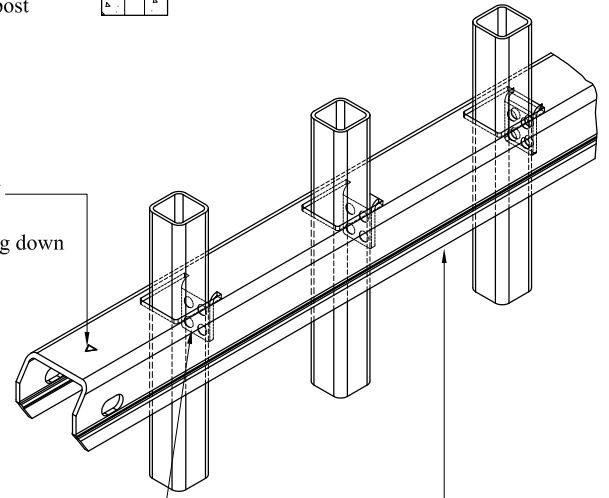

PROFUSION™ WELDING PROCESS

No exposed welds,
 Good Neighbor profile - Same appearance on both sides

MONTAGE II™ RAIL
 Specially formed high strength architectural shape.

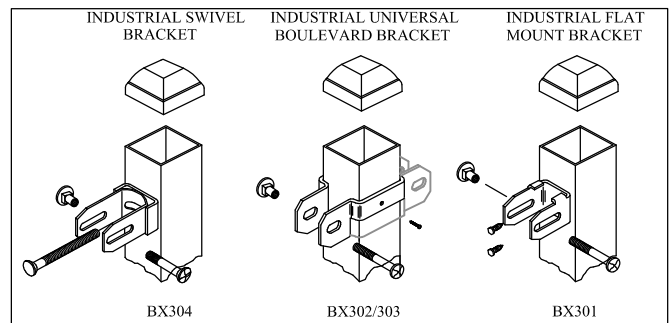
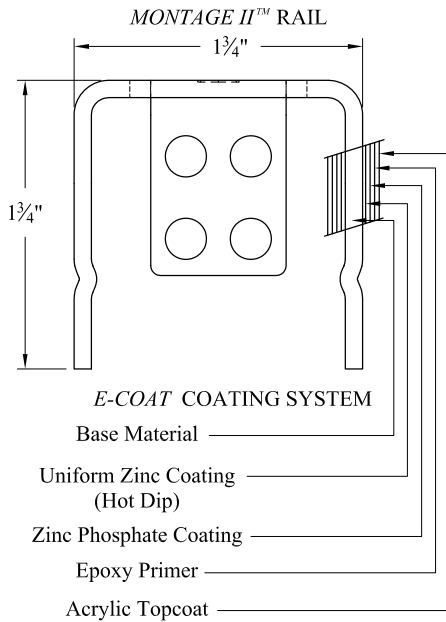

HEAVY INDUSTRIAL STRENGTH WELDED STEEL PANEL
PRE-ASSEMBLED

Values shown are nominal and not to be used for installation purposes. See product specification for installation requirements.

2HGISO

Title: MONTAGE II GENESIS 2/3/4-RAIL		
DR: RTM	SH . 1 of 1	SCALE: DO NOT SCALE
CK: ME	Date 6/25/10	REV: b



AMERISTAR®

1555 N. Mingo
 Tulsa, OK 74116
 1-888-333-3422
 www.ameristarfence.com