

- NO RIVETS
- NO SCREWS
- NO WELDS

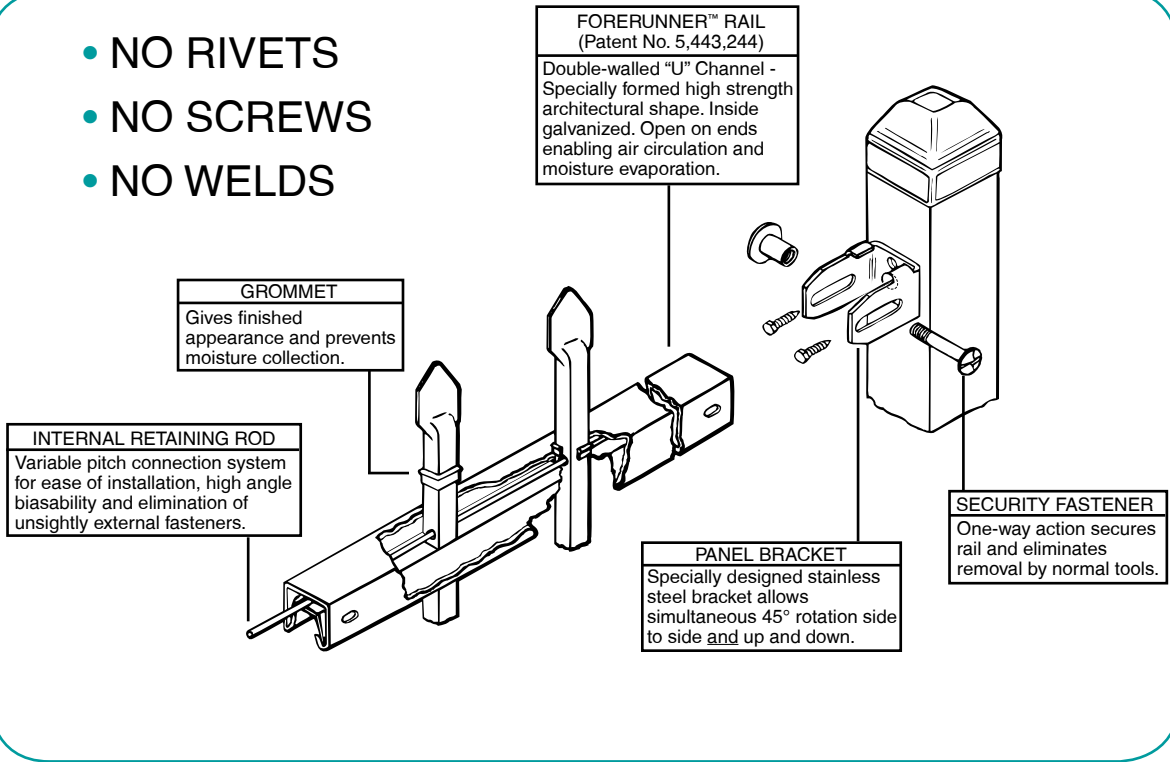

Picket To Rail

ForeRunner™ Rail
with Enclosed Retaining Rod

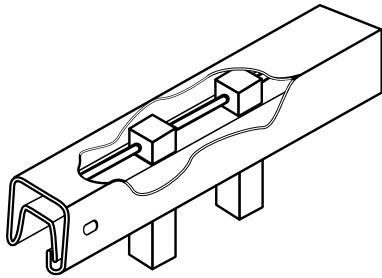

Rod is completely enclosed.
Attachment cannot be compromised.

Rail To Bracket

Security Fastener

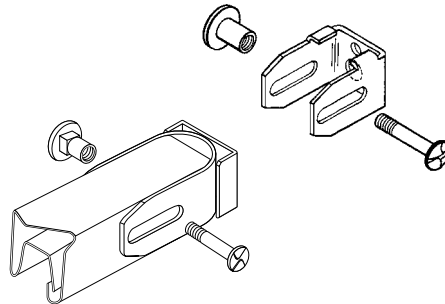

One-way fastener cannot be loosened by normally available tools.