

TRANSPORT II

U.S.A. Patent Number 5,136,813

ORNAMENTAL CANTILEVER GATE INSTRUCTIONS

*NOTICE: Ornamental Cantilever Gates are supplied with rolls of 2" mesh safety screening in sufficient quantities to cover the entire gate (including overhang) and an equal portion of fence parallel to the gate in the open position up to a height of over 6 feet from ground elevation. This screening must be included when the TransPort Gate is assembled at the jobsite. Additionally, all of the safety requirements of ASTM F2200 must be met during installation. Failure to incorporate the safety mesh or follow ASTM F2200 safety requirements during gate assembly and installation will cause rejection (under UL-325) of the entire gate system any time an attempt is made to attach the gate to an automatic gate operator. Ameristar assumes no responsibility for gate installations that fail to utilize the materials provided or meet the applicable safety standards.

1. All gates require two 4" square truck bracket mounting posts, one to act as Fulcrum Post, the second as Tail Support Post. Set these mounting posts in an off-line configuration as shown in Figure 1. Check grade conditions to ensure posts are set to proper height; allow no more than four (4) inches from bottom of gate to grade. A Supplemental Latch Post, located as shown in Figure 1, is required to mount patented offset latches (see Step 11 - Page 5).

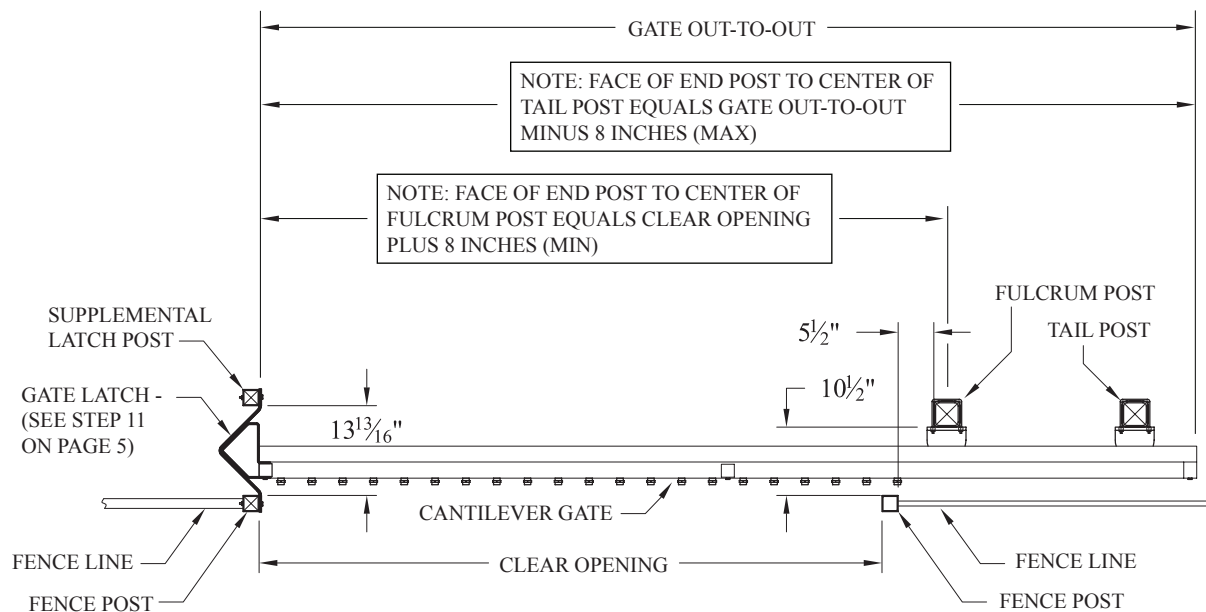

FIGURE 1

2. Remove all gate components including tracks, uprights, diagonal braces, pickets, hardware and safety accessories. Spread out neatly, preferably in a large flat clean area. Use wood pallets, or studs to keep items from coming in contact with ground. Check quantities against appropriate gate opening on Parts List below.

PARTS LIST

Gate Opening		6' TO 8'	> 8' TO 10'	> 10' TO 12'	> 12' TO 14'	> 14' TO 16'	> 16' TO 18'	> 18' TO 20'	> 20' TO 22'	> 22' TO 24'	> 24' TO 27'	> 27' TO 30'			
Gate Out-To-Out		144½"	182½"	211"	249"	287"	325"	372½"	401"	429½"	496"	534"			
Components	Part														
	A1	Top Track	1	1	1	1	1	1	1	1	1	1	1	1 Short Left	1 Short Left
	A2		-	-	-	-	-	-	-	-	-	-	-	1 Long Right	1 Long Right
	A3	Bottom Track	1	1	1	1	1	1	1	1	1	1	1	1 Long Left	1 Long Left
	A4		-	-	-	-	-	-	-	-	-	-	-	1 Short Right	1 Short Right
	B	Uprights 2" SQ	3	3	5	5	5	5	7	7	7	9	9		
	C	Diagonals 2" SQ (Plated)	2	2	4	4	4	4	6	6	6	8	8		
	D	Pickets 1" SQ	21	27	31	37	42	48	55	59	63	73	79		
	E1	Frame Bolts 3/8" x 3"	16	16	32	32	32	32	48	48	48	68	68		
	E2	Splice Bolts 3/8" x 4"	-	-	-	-	-	-	-	-	-	6	6		
	F	All-Thread Bolt 3/8" x 3-1/2"	2	2	2	2	2	2	2	2	2	2	2		
	G	Picket Bolts 1/4" x 1-1/2"	42	54	62	74	84	96	110	118	126	146	158		
	H	Frame Nuts 3/8" Lock Nut	20	20	36	36	36	36	52	52	52	78	78		
I	Picket Nuts 1/4" Lock Nut	42	54	62	74	84	96	110	118	126	146	158			
J	Flat Washers - 3/8"	36	36	68	68	68	68	100	100	100	154	154			
Hardware TGKODN	Truck Assemblies	4	4	4	4	4	4	4	4	4	4	4			
	Truck Brackets	4	4	4	4	4	4	4	4	4	4	4			
	Gate Latch	2	2	2	2	2	2	2	2	2	2	2			
	Gate Stops	4	4	4	4	4	4	4	4	4	4	4			
Safety	K	Safety Mesh	50' Roll	50' Roll	50' Roll	50' Roll	50' Roll	100' Roll	100' Roll	100' Roll	100' Roll	100' Roll	100' Roll	100' Roll	

3. For gate openings greater than 24 feet, tracks are required to be spliced. Align short left track (A1) to long right track (A2) and insert splice block as shown in Figure 2A. Line up pre-drilled holes, attach with frame bolts (E1), splice bolts (E2), flat washers (J), and frame nuts (H). Tighten all nuts thoroughly. Align long left track (A3) to short right track (A4) and insert splice block as shown in Figure 2B. Line up pre-drilled holes, attach with frame bolts (E1), splice bolts (E2), flat washers (J), and frame nuts (H). Tighten all nuts thoroughly.

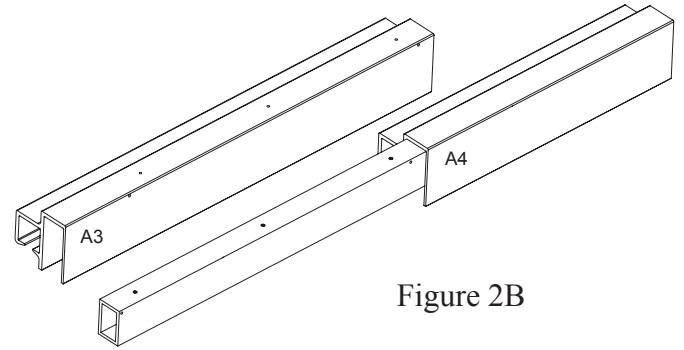
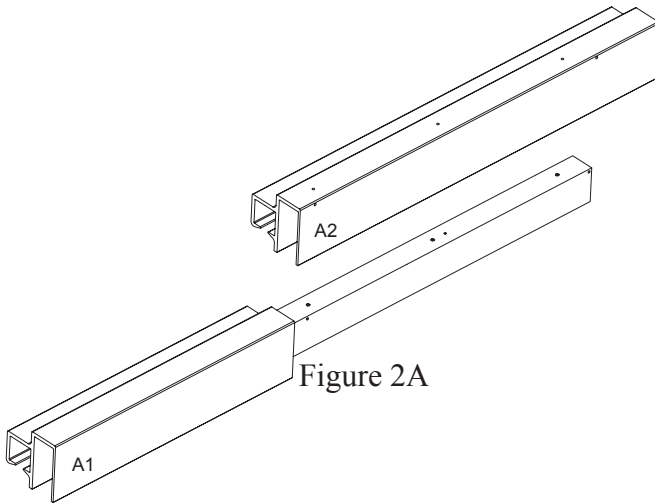

4. Position top and bottom tracks parallel to each other. Allow sufficient space to layout uprights between and perpendicular to tracks (see Figure 3). Use diagram in Appendix 1 (Page 6) to ensure correct location and orientation of each upright. Slide uprights into top track and align with pre-drilled holes. Attach with frame bolts (E), flat washers (J), and frame nuts (H). Finger tighten. Bring bottom track over bottom of uprights and align with pre-drilled holes. Attach with frame bolts (E), flat washers (J), and frame nuts (H). Finger tighten.

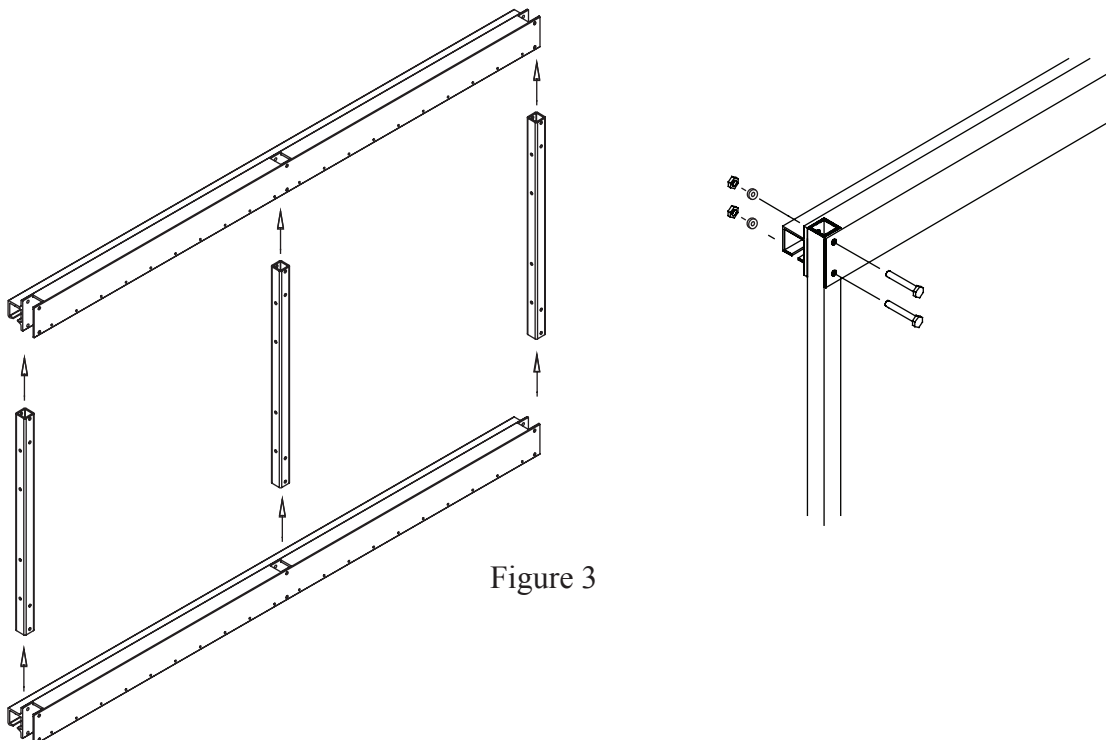

- Position diagonal braces in bays between uprights; use diagram in Appendix 1 (Page 6) to ensure correct location and orientation of each diagonal. At top of center upright, attach the two mating diagonals using all thread bolts (F), flat washers (J), and frame nuts (H) as shown in Figure 4. At all other diagonal to upright connections, attach with frame bolts (E), flat washers (J), and frame nuts (H). Tighten all nuts thoroughly.

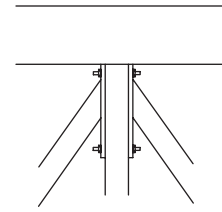

Figure 4

- Square the gate by measuring from corner to corner on frame as shown in Figure 5. Dimensions “X” and “Y” should be equal (+/- 1/4”) Tighten all nuts thoroughly.

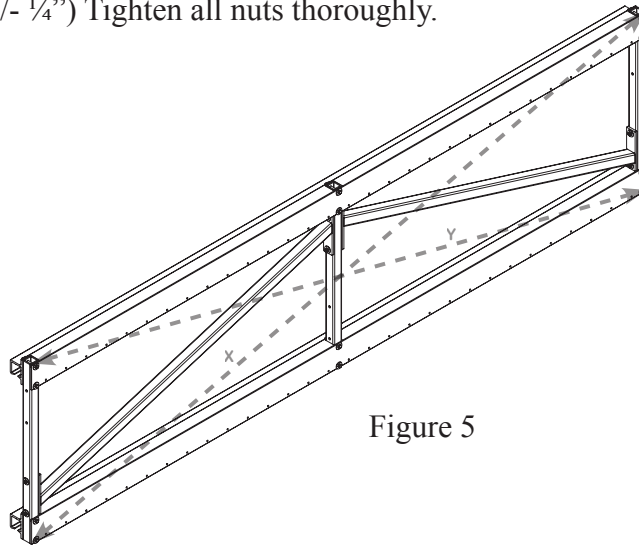

Figure 5

- Attach safety mesh (K) to bottom 6’ of gate (Note: Fasteners are not provided; installer is responsible for attachment method). Sufficient mesh is provided to also cover fence that runs parallel to gate travel path.

- Track is predrilled its entire length so that pickets (D) can be attached either left or right depending on the direction of the gate opening. If gate opens to the right, install pickets from left end; if gate opens to the left, install pickets from the right end. Position pickets (D) to align with pre-drilled holes in tracks, attach with picket bolts (G) and picket nuts (I) as shown in Figure 6. Tighten all nuts thoroughly.

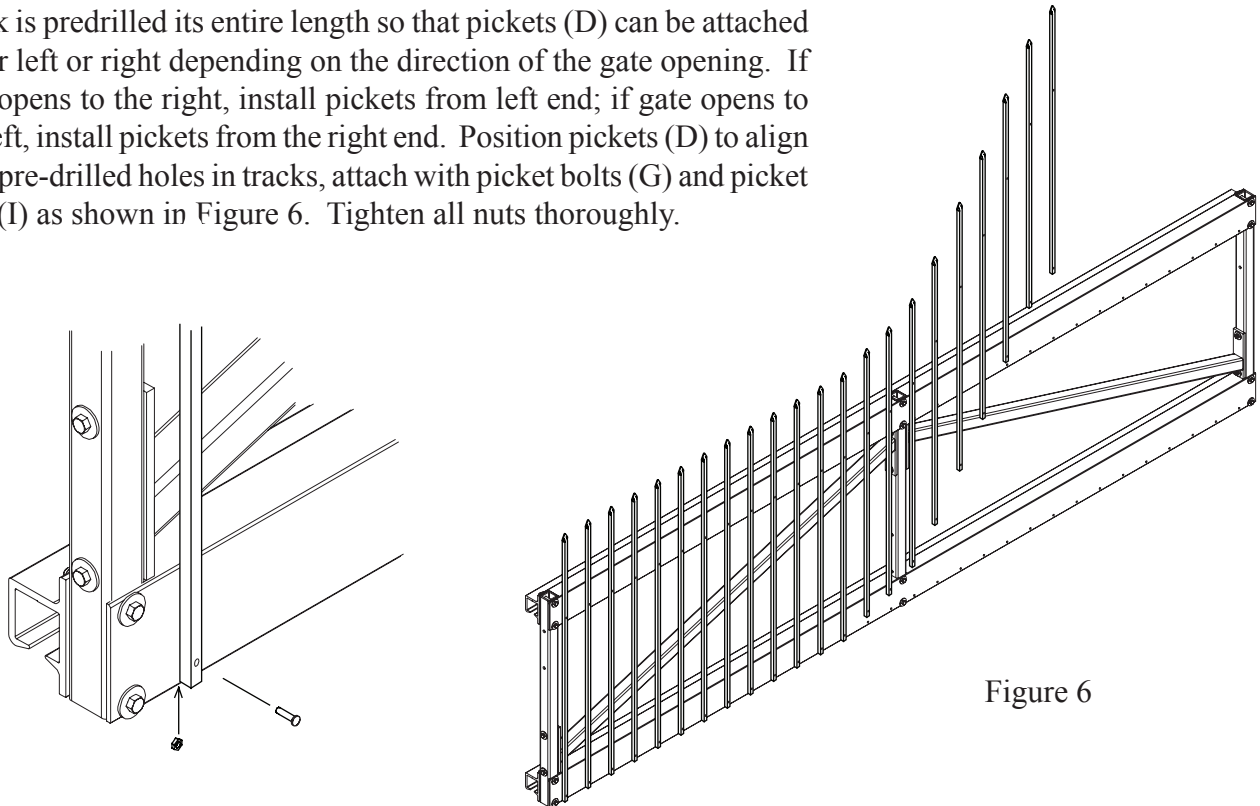

Figure 6

9. Un-package the truck assembly hardware kits (TGKOD). Install truck assemblies onto truck brackets as shown in Figure 7A, leaving 1" of thread above bracket. Install truck assembly brackets on gateposts facing the public side of the gate, utilizing u-bolts provided, aligning them so that gate will hang level horizontally, with bottom of gate no more than 4" above grade. Tighten truck assembly brackets nuts See Figure 7B.

Figure 7A

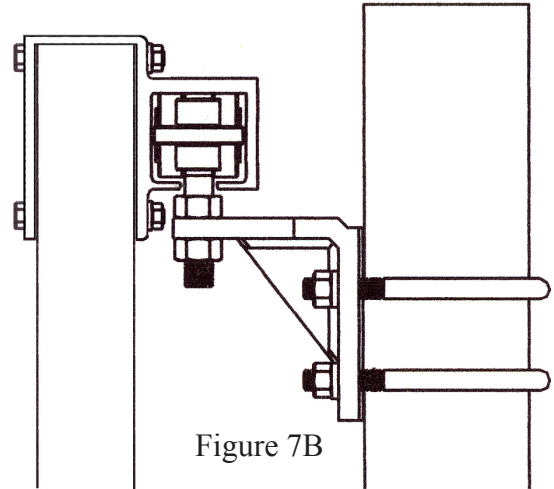
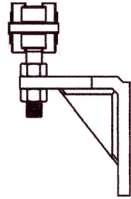

Figure 7B

10. Stand the gate upright, being careful not to twist the gate or cause the track to bend. This is most easily accomplished by lifting the top of the gate at two or more equally divided locations (not at the ends) and leaning it against a rigid structure. Keeping the gate upright without twisting, move the gate so that the trailing edge is in line with the first post (closest to the opening); then lift the end of the gate so that the upper and lower track raceways slide onto the first set of truck assemblies. Raise the opposite end of the gate and continue sliding the gate until it engages the second set of truck assemblies. Continue to slide gate to the half-open position. Install gate stops in the raceway of the track on the leading and trailing edges of gate. See Figure 8.

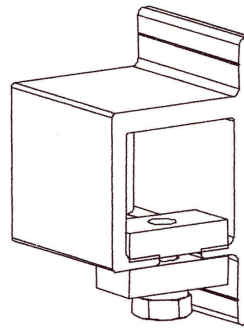

Figure 8

11. To mount the two (2) gate latches, begin by sliding the gate to the fully closed position. Install the guides on the leading edge of the gate, just below top track and just above bottom track, using fasteners provided. Attach the receiver assemblies to the tandem receiver posts so that they are aligned with the guides. See Figure 9.

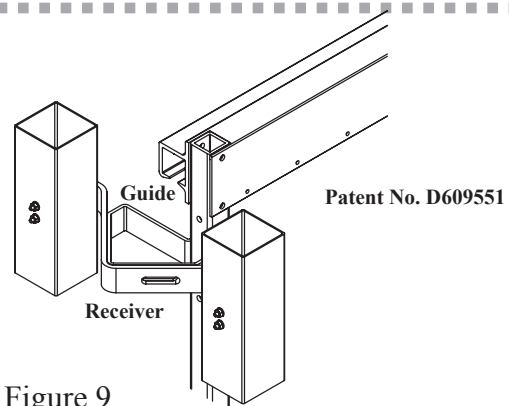
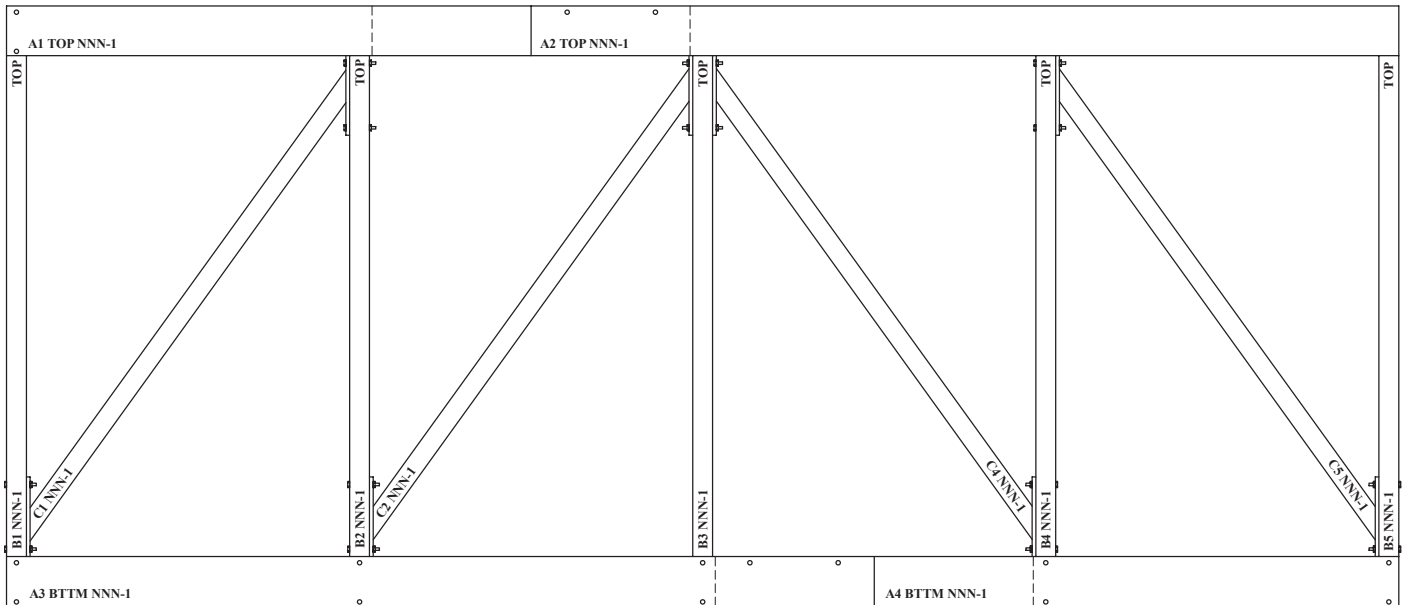

Figure 9

APPENDIX 1

Part Identification, Location & Orientation Diagram



Tracks: Top and Bottom Tracks are labeled in the bottom left corner on the front face of the track. For gate openings up to and including 24’, there will be a single top track identified as ‘A1’ and a single bottom track identified as ‘A3’. For gate openings over 24’, it is necessary to splice Parts ‘A1’ (short left) and ‘A2’ (long right) as shown in Figure 2A (Page 3) and to splice Parts ‘A3’ (long left) and ‘A4’ (short right) as shown in Figure 2B (Page 3). Each track part will also be marked with a three digit number (the last 3 digits of the work order), followed by a hyphen and a unique number starting with ‘1’ and then proceeding integrally if necessary to identify each gate where there are multiple gates on the order.

Uprights: All Uprights are labeled with an identifier beginning with a ‘B’, followed by a number beginning with ‘1’ and proceeding integrally from left to right (with track face up). Each upright will also be marked with a three digit number (the last 3 digits of the work order), followed by a hyphen and a unique number starting with ‘1’ and then proceeding integrally if necessary to identify each gate where there are multiple gates on an order. The top of each upright will be marked “TOP”.

Diagonals: All Diagonals are labeled with an identifier beginning with a ‘C’, followed by a number corresponding to the numbered upright that it is to be connected to at the bottom of the gate (e.g., C1 attaches to B1, C2 attaches to B2, etc.). Each diagonal will also be marked with a three digit number (the last 3 digits of the work order), followed by a hyphen and a unique number starting with ‘1’ and then proceeding integrally if necessary to identify each gate where there are multiple gates on an order.