

# PASSPORT

## ROLL GATES



### THE TRADITIONAL ENTRY GATE SOLUTION

The PassPort roll gate system has been redesigned to fit a wide variety of heights and openings. The PassPort v-track design provides the least amount of space required for a slide gate and the greatest installation flexibility.

#### ROBUST

PassPort II is an innovative roll gate system with a robust fabricated design. The PassPort roll gates have a rigid framework that enables the gate system to glide effortlessly across its on-grade track.

#### VERSATILE

All PassPort gates are designed with versatility in mind. The reversible design of the PassPort roll gate insures a flawless installation by allowing the gate to be installed on either side of the gate opening.

#### DURABLE

PassPort's fully welded construction and PermaCoat finish give this V-track roll gate the durability and strength required for limitless gate cycles.



We take great pride in manufacturing "Made in the USA" products. Ameristar is

located in Tulsa, Oklahoma and is American owned and operated.

#### Applications:

- Water Treatment & Storage
- Municipal Facilities
- Government Facilities
- Airports
- Manufacturing Plants
- Petroleum & Chemical Facilities
- Power Plants & Substations
- Schools & Universities
- Stadiums & Event Centers

# PASSPORT

## ROLL GATES

### TYPES

PassPort Commercial - 3/4" Ornamental Picket Design

Styles: Classic, Majestic, Genesis, Invincible (shown)

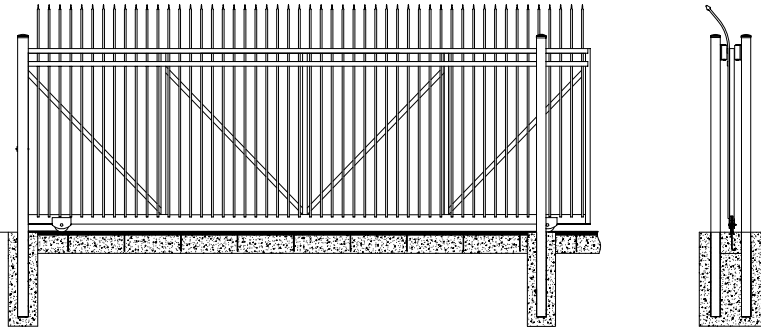

PassPort Estate - 1" Ornamental Picket Design

Styles: Majestic, Genesis, Invincible, Classic (shown)

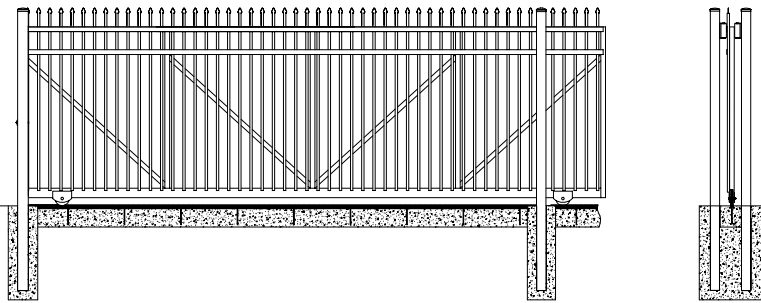

PassPort IS - 2-3/4" Ornamental Pale Design

Styles: Trident, Stronghold, Gauntlet (shown)

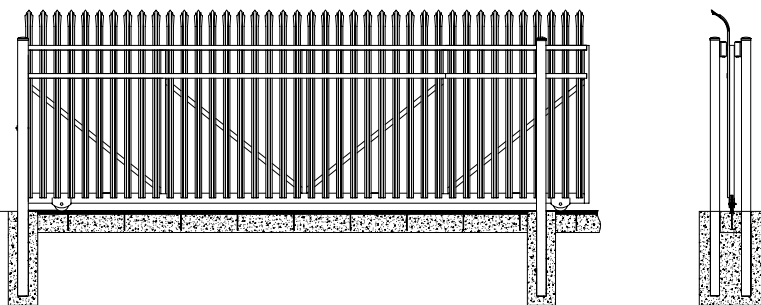

Ameristar's design team has improved its sliding gates to comply with the latest industry standards. PassPort roll gates are designed to comply with ASTM F2200.

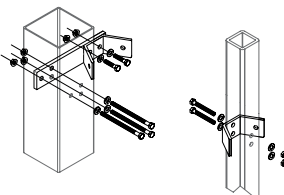

### DESIGN

Fully Welded Steel Construction

Uprights: 2" sq. x 11ga.

Diagonal Bracing: 2" sq. x 11ga.

Bottom Rail: 2" x 4" x 11ga.

Minimum 4" x 11ga. gate posts

### HARDWARE

The PassPort roll gate design has been matched with equally superior hardware. The v-track rollers are designed to support more than the recommended load, and provide an effortless balance that glides smoothly across its gate opening.

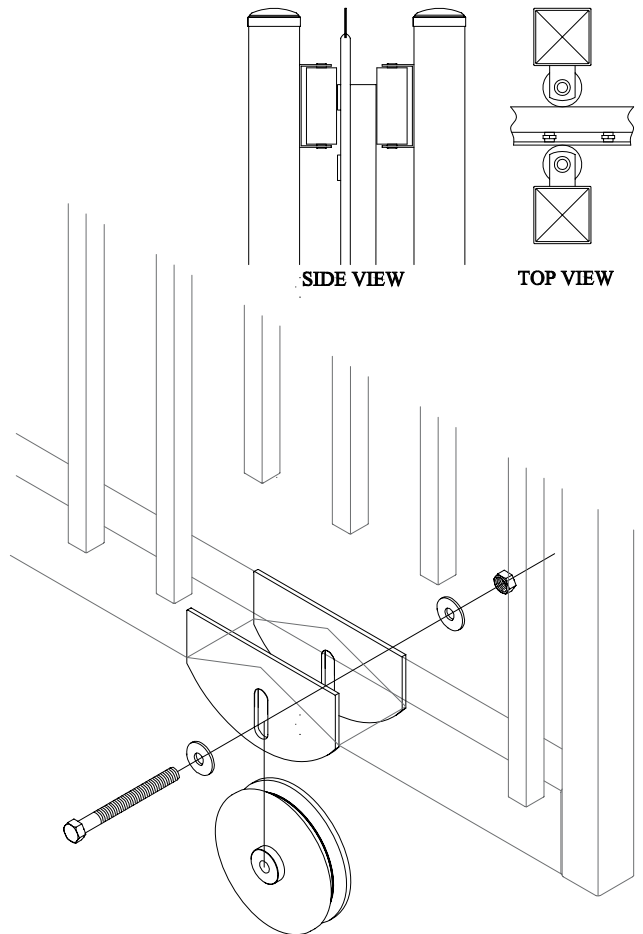

Item No. 9797 / Effective: 11/2011