

**NOTES:**

1. Post footing available in 21" or 33" depths.

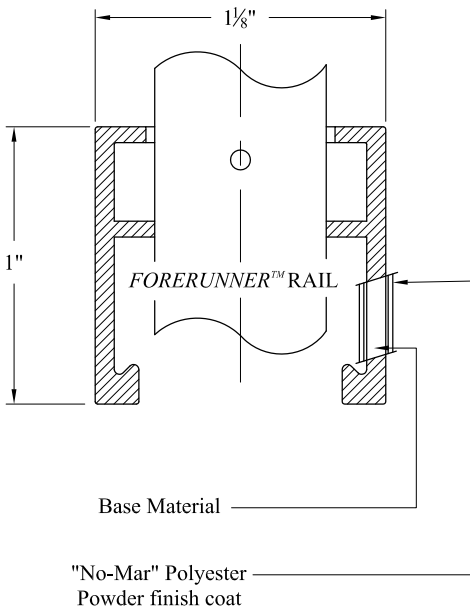

**INTERNAL RETAINING ROD**

Variable pitch connection system for ease of installation, high angle bias ability and elimination of unsightly external fasteners.

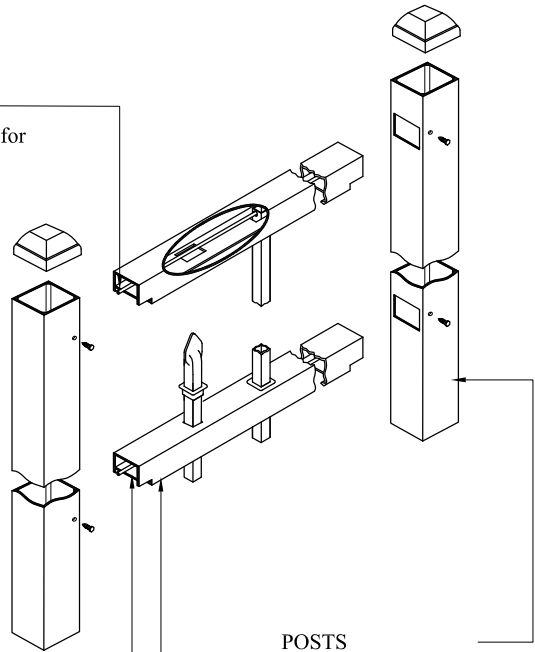

**INTERIOR GUIDE CHANNEL**  
Channel forms lower limit of raceway for retaining rod and allows for high angle bias ability.

**FORERUNNER™ RAIL**  
"U"-Channel specially formed high strength architectural shape.

**POSTS**

Special extruded aluminum shape with reinforced corners; pre-punched to eliminate brackets.

Values shown are nominal and not to be used for installation purposes. See product specification for installation requirements.

RISO

Title: **ECHELON CONQUEROR 3-RAIL**

DR: CI    SH . 1 of 1    SCALE: DO NOT SCALE

CK: ME    Date 6/25/10    REV: b



**AMERISTAR®**

1555 N. Mingo  
Tulsa, OK 74116  
1-888-333-3422

www.ameristarfence.com