

NOTES:

1. Post footing available in 21" or 33" depths.

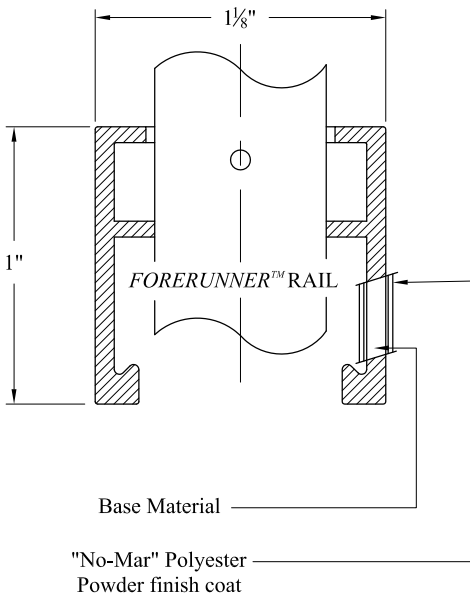

INTERNAL RETAINING ROD

Variable pitch connection system for ease of installation, high angle bias ability and elimination of unsightly external fasteners.

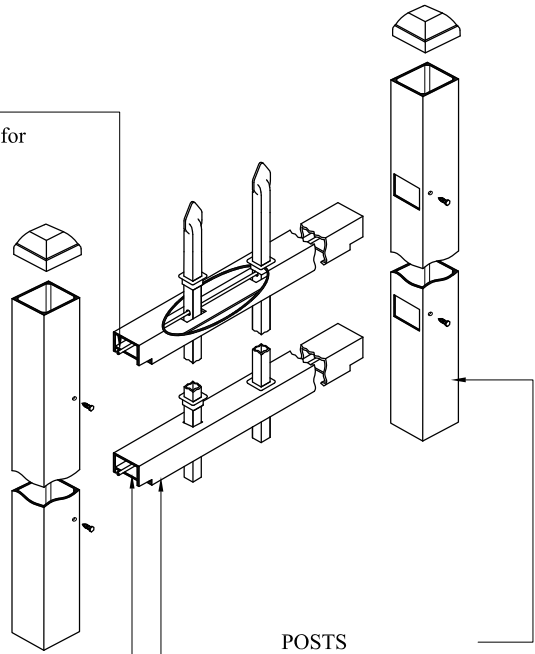

INTERIOR GUIDE CHANNEL
Channel forms lower limit of raceway for retaining rod and allows for high angle bias ability.

FORERUNNER™ RAIL
"U"-Channel specially formed high strength architectural shape.

POSTS

Special extruded aluminum shape with reinforced corners; pre-punched to eliminate brackets.

Values shown are nominal and not to be used for installation purposes. See product specification for installation requirements.

CISO

Title: **ECHELON CLASSIC 3-RAIL**

DR: CI SH . 1 of 1 SCALE: DO NOT SCALE

CK: ME Date 6/25/10 REV: b



AMERISTAR®

1555 N. Mingo
Tulsa, OK 74116
1-888-333-3422
www.ameristarfence.com