

**NOTES:**

- 1.) Post size depends on fence height and wind loads. See **ECHELON Plus™** post sizing chart.
- 2.) Panels also available for 6' on center post spacing
- 3.) Additional heights available on request
- 4.) Fourth rail optional.

**RING OPTION**

Held in place with upper and lower internal retaining rods to eliminate unsightly external fasteners.

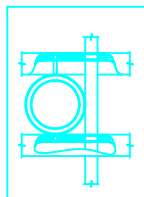

**PANEL BRACKET**

Specially designed two-point connection ensures fixity of rail ends for increased strength.

**INTERNAL RETAINING ROD**

Variable pitch connection system for ease of installation, high angle bias ability and elimination of unsightly external fasteners.

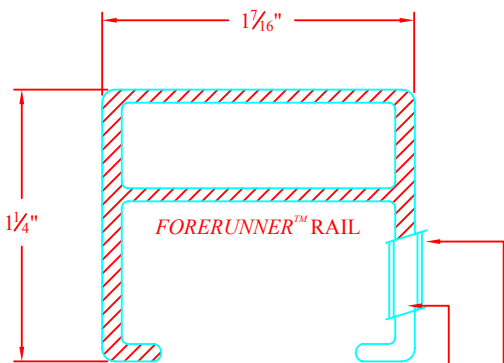

Base Material

"No-Mar" Polyester Powder finish coat

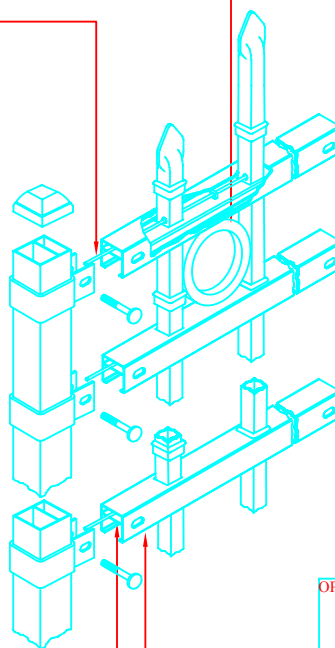

**REINFORCED POST**

Internal rib increases against wind loading as well as other horizontally applied forces (Only on 2 1/2" aluminum posts).

**INTERIOR GUIDE CHANNEL**  
Channel forms lower limit of raceway for retaining rod and allows for high angle bias ability.

**FORERUNNER™ RAIL**

"U"-Channel specially formed high strength architectural shape.

**OPTIONAL LINE BOULEVARD BRACKET**

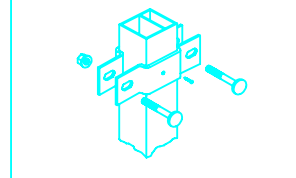

Values shown are nominal and not to be used for installation purposes. See product specification for installation requirements.

**COMMERCIAL STRENGTH ALUMINUM**

Title: **ECHELON PLUS WARRIOR 3/4-RAIL W/RING OPTION**

DR: JAS SH. 1 of 1 SCALE: DO NOT SCALE

CK: BS Date 05/02/12 REV: e



**AMERISTAR™**

1555 N. Mingo  
Tulsa, OK 74116  
1-888-333-3422  
www.ameristarfence.com

AWISO