

**NOTES:**

- 1.) Post size depends on fence height and wind loads. See *ECHELON Plus™* post sizing chart.
- 2.) Panels also available for 6' on center post spacing
- 3.) Additional heights available on request
- 4.) Fourth rail optional.

**PANEL BRACKET**

Specially designed two-point connection ensures fixity of rail ends for increased strength.

**INTERNAL RETAINING ROD**

Variable pitch connection system for ease of installation, high angle bias ability and elimination of unsightly external fasteners.

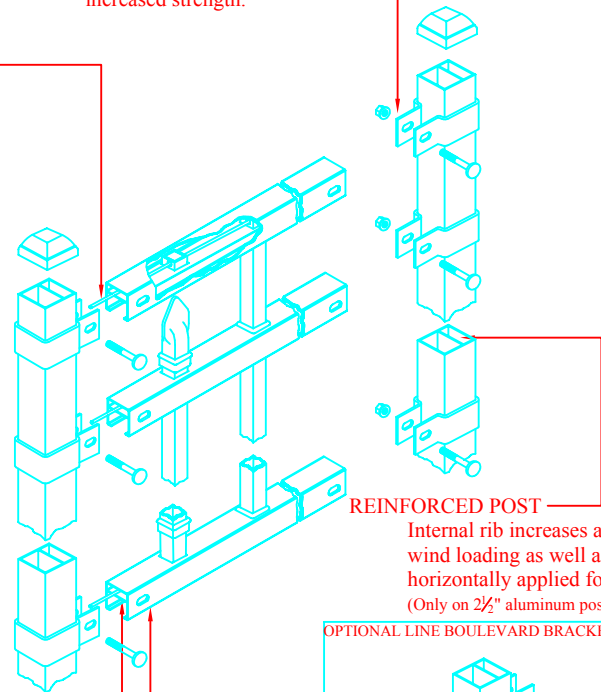
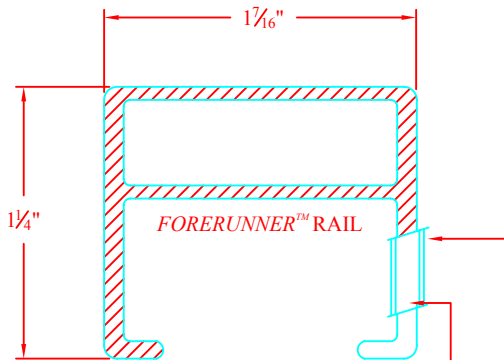

**INTERIOR GUIDE CHANNEL**  
Channel forms lower limit of raceway for retaining rod and allows for high angle bias ability.

**FORERUNNER™** RAIL  
"U"-Channel specially formed high strength architectural shape.

Values shown are nominal and not to be used for installation purposes. See product specification for installation requirements.

**COMMERCIAL STRENGTH ALUMINUM**

Title: <b>ECHELON PLUS CONQUEROR 3/4-RAIL POOL</b>			
DR: JAS	SH. 1 of 1	SCALE: DO NOT SCALE	
CK: BS	Date 05/02/12	REV: e	



**AMERISTAR®**

1555 N. Mingo  
Tulsa, OK 74116  
1-888-333-3422  
www.ameristarfence.com