

MONTAGE II

INDUSTRIAL WELDED STEEL ORNAMENTAL FENCE



THE ORNAMENTAL IRON STANDARD

As the world's leader in ornamental fencing Ameristar Fence Products continues to deliver value added products that outperform industry standards. Montage II is the preferred choice among owners, architects, and contractors for industrial ornamental fence.

STRENGTH

Montage II is manufactured using a proven fusion welding technology. The welded design of Montage II bonds the industrial pickets at each rail intersection delivering unmatched strength.

APPEAL

Montage II is available in multiple styles and heights to match any project requirement. The 1" steel picket design of Montage II delivers a versatile appeal by combining security with aesthetics.

DESIGN

The Montage II ATF (all terrain fence) design can traverse over a 50% grade change. Ameristar's E-Coat coating process protects Montage II from weathering, guaranteeing long lasting beauty and structural integrity providing a 20 year warranty.



We take great pride in manufacturing "Made in the USA" products. Ameristar is

located in Tulsa, Oklahoma and is American owned and operated.

Applications:

- State Facilities
- Municipal Facilities
- Airports
- Water Treatment & Storage
- Public Housing Authorities
- Parks & Recreation
- Stadiums & Event Centers
- Schools & Universities
- Hospitals

Covered by or for use with one or more of the following U.S. patents: 6.811.145, 7.071.439, 7.159.853, 7.282.659, 7.396.002, 7.621.510



MONTAGE II

INDUSTRIAL WELDED STEEL ORNAMENTAL FENCE

PANELS

Montage II panels are welded using pro-fusion technology, a process proven in the automotive and aerospace industries.

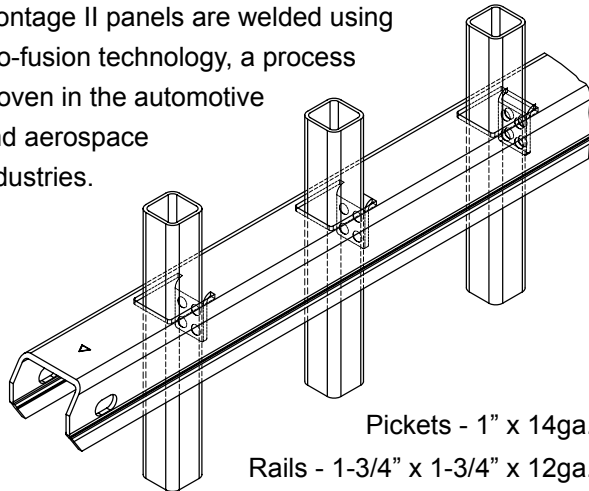

POSTS

Posts are manufactured of high tensile steel and are galvanized inside and out for superior corrosion protection. Industrial strength posts are recommended for Montage II: 2-1/2" Sq. x 12ga. & 3" Sq. x 12ga.

BRACKETS

Montage II brackets are designed of high strength stainless steel and accompanied with tamper-proof fasteners. Ameristar's bracketed design allows the contractor to have a flawless installation and helps maintain the integrity of the coating by not welding the panels to the posts.

GATES

Ameristar understands the importance of balancing perimeter security with the highest quality entry control gates. Montage II has a wide variety of Swing, Slide, and Cantilever Gates to match any entry.



Montage II is produced using up to 96% post-industrial recycled steel.

WARRANTY

Montage II is produced in a state-of-the-art manufacturing facility using the highest quality materials and processes. Ameristar has over 25 years of experience and research in coating and processing of ornamental fence products allowing Montage II to support a 20 year warranty.

COATING

Ameristar has always challenged the industry by developing and producing products with superior coatings. Montage II was developed using E-Coat technology which deposits coatings throughout the entire product, thus eliminating any risk of corrosion where typical powders will not adhere.

STYLES

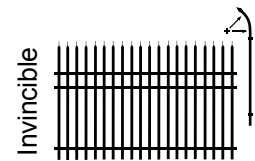
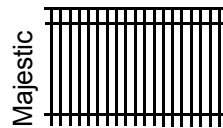
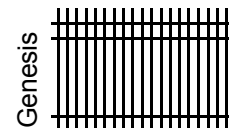
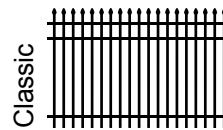

Item No. 9790 / Effective: 10/2011

